

Grand Parade 2  
Floorplans  
(Floors 37-49)



ONE BEDROOM  
+ DEN  
Suite 01

NET SUITE AREA / 638 SQ.FT.

BALCONY AREA / 35 SQ.FT.

TOTAL NET AREA / 673 SQ.FT.

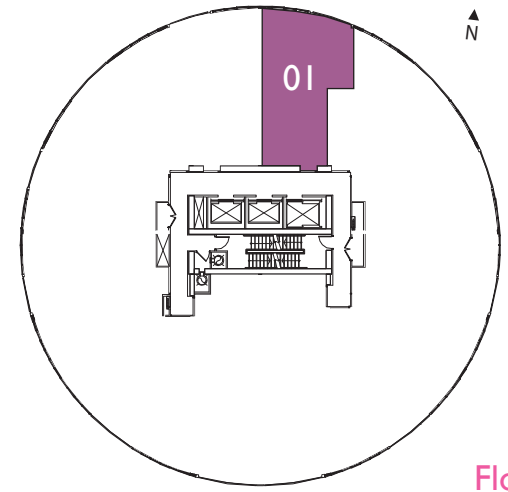

Floors 37-49

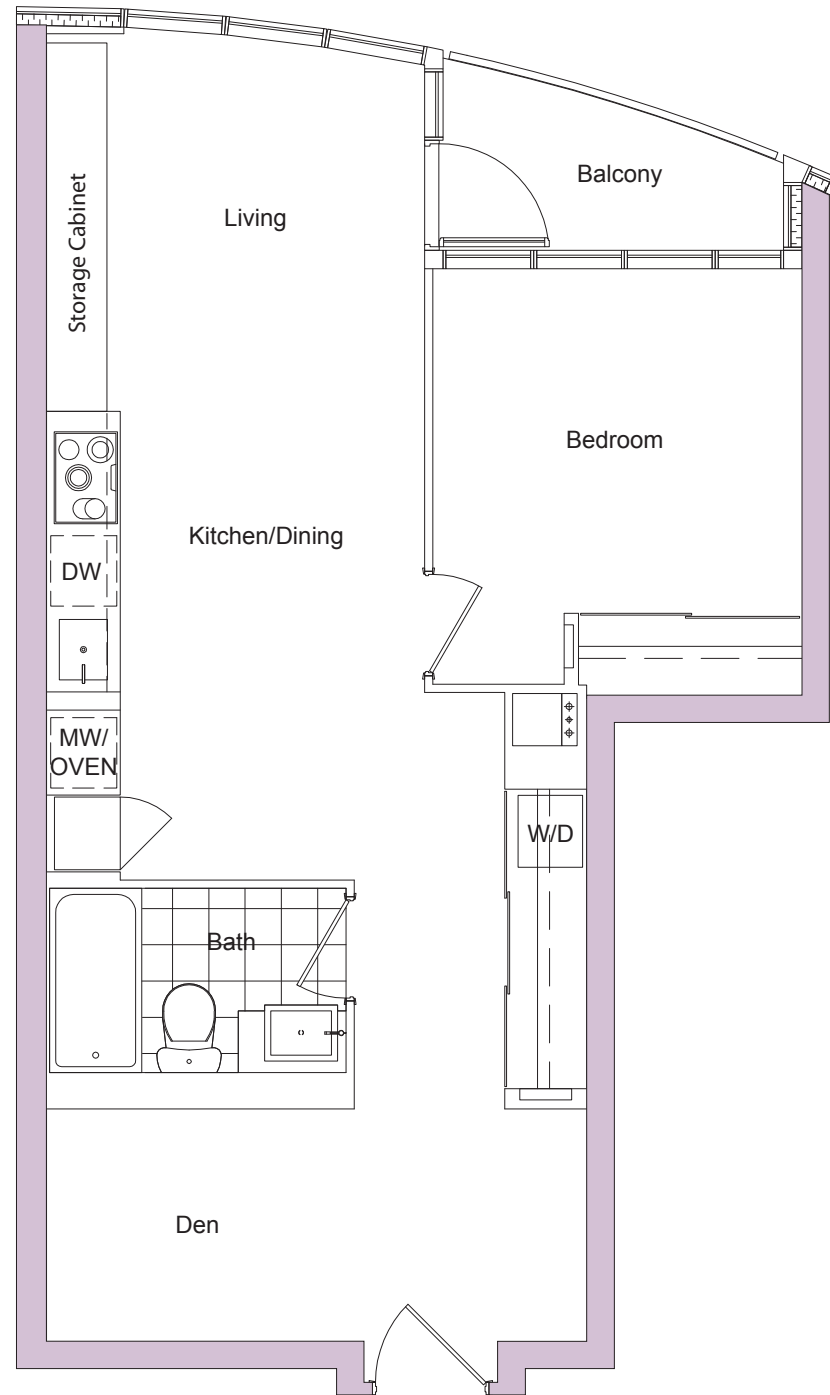

The developer reserves the right to make minor revisions to interior wall locations and exterior window system. All materials and drawing are approximate. Information is subject to change without notice. Actual square footage may vary from the stated floor plan. E. & O.E.



# ONE BEDROOM

Suite 02

NET SUITE AREA / 550 SQ.FT.

BALCONY AREA / 35 SQ.FT.

TOTAL NET AREA / 585 SQ.FT.

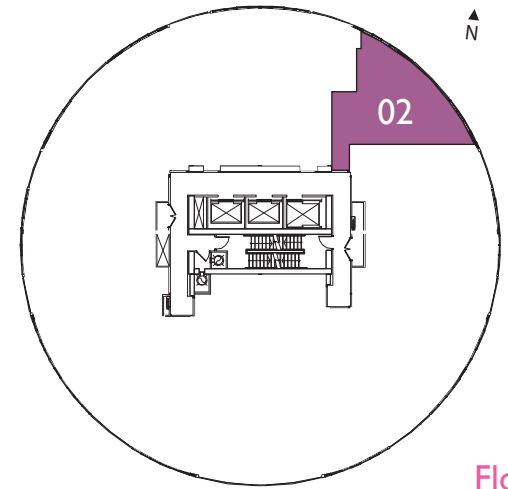

Floors 37-49

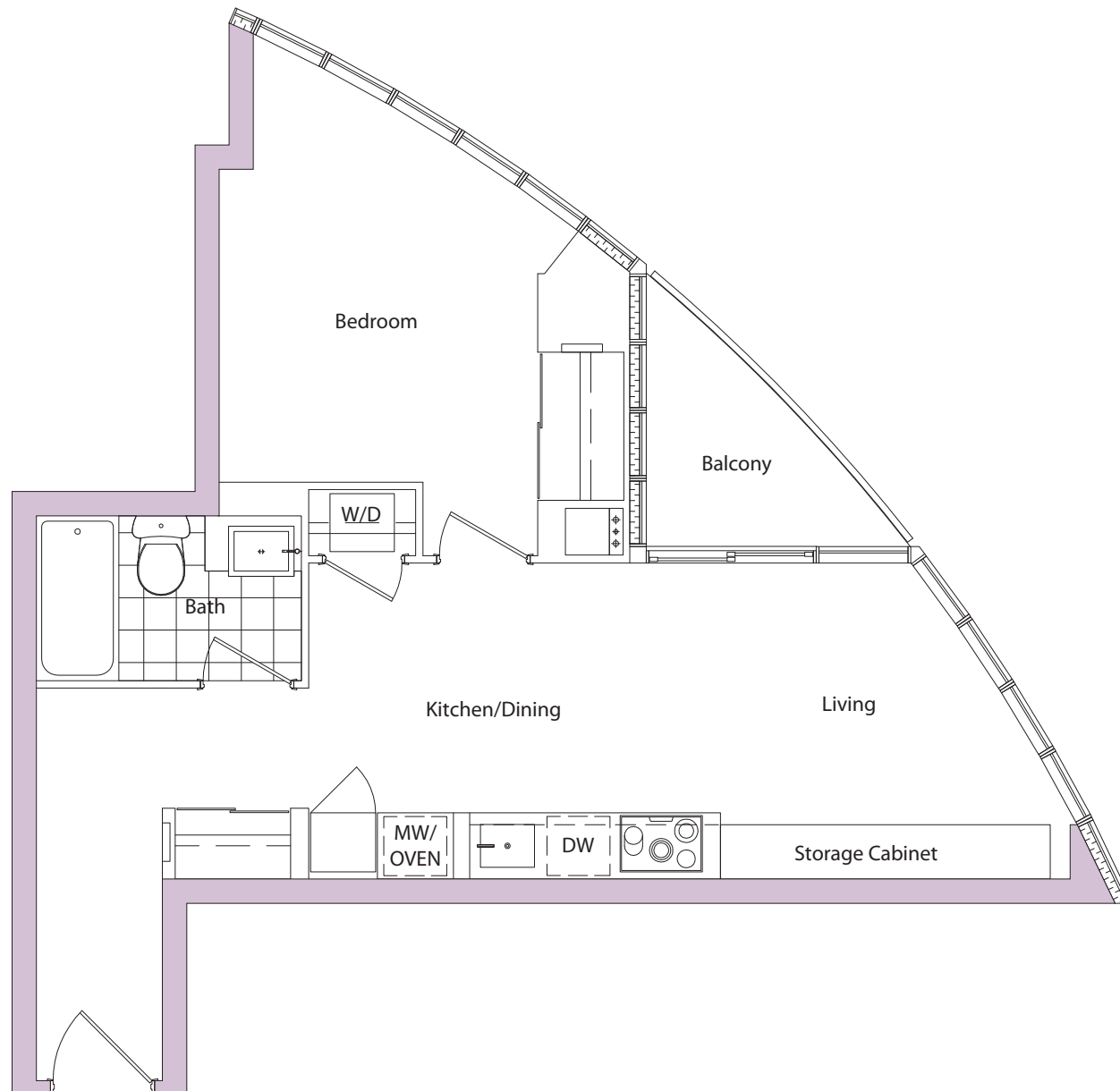

ONE BEDROOM  
+ DEN  
Suite 03

NET SUITE AREA / 573 SQ.FT.  
BALCONY AREA / 35 SQ.FT.  
TOTAL NET AREA / 608 SQ.FT.

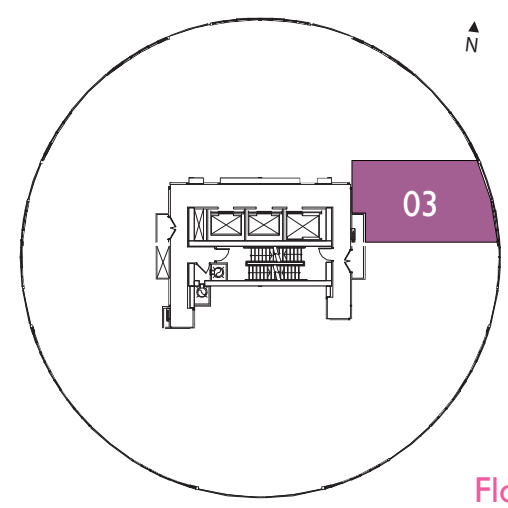

Floors 37-49

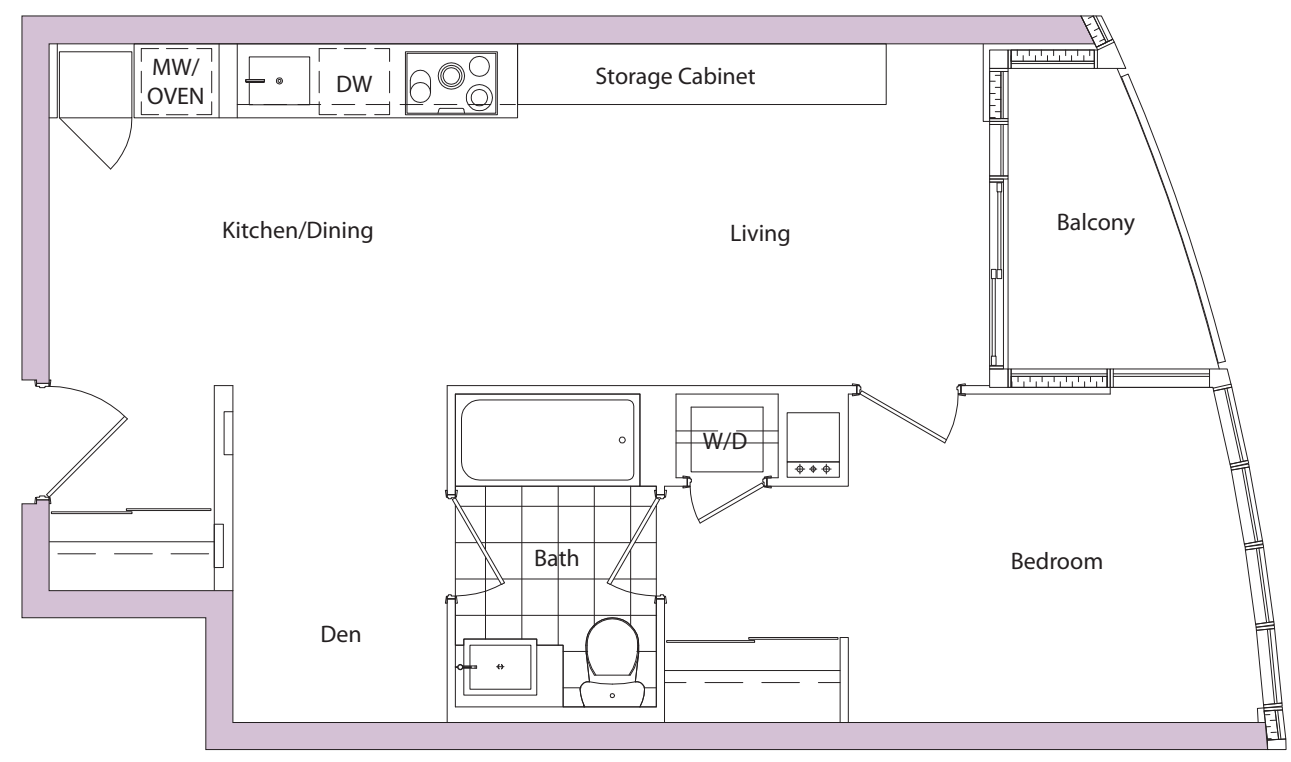

The developer reserves the right to make minor revisions to interior wall locations and exterior window system. All materials and drawing are approximate. Information is subject to change without notice. Actual square footage may vary from the stated floor plan. E. & O.E.

TWO BEDROOM  
+ FAMILY ROOM

Suite 06

NET SUITE AREA / 1,432 SQ.FT.

BALCONY AREA / 98 SQ.FT.

TOTAL NET AREA / 1,530 SQ.FT.

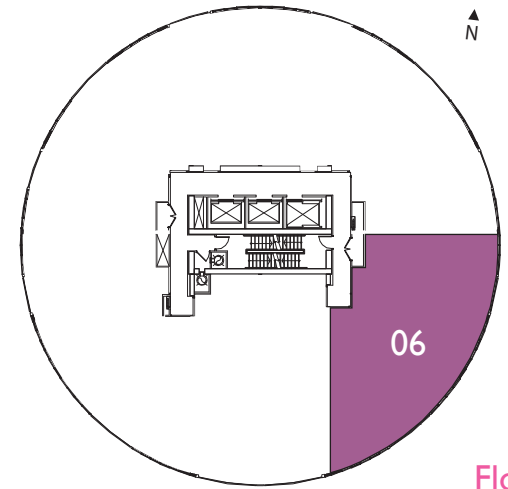

Floors 37-48

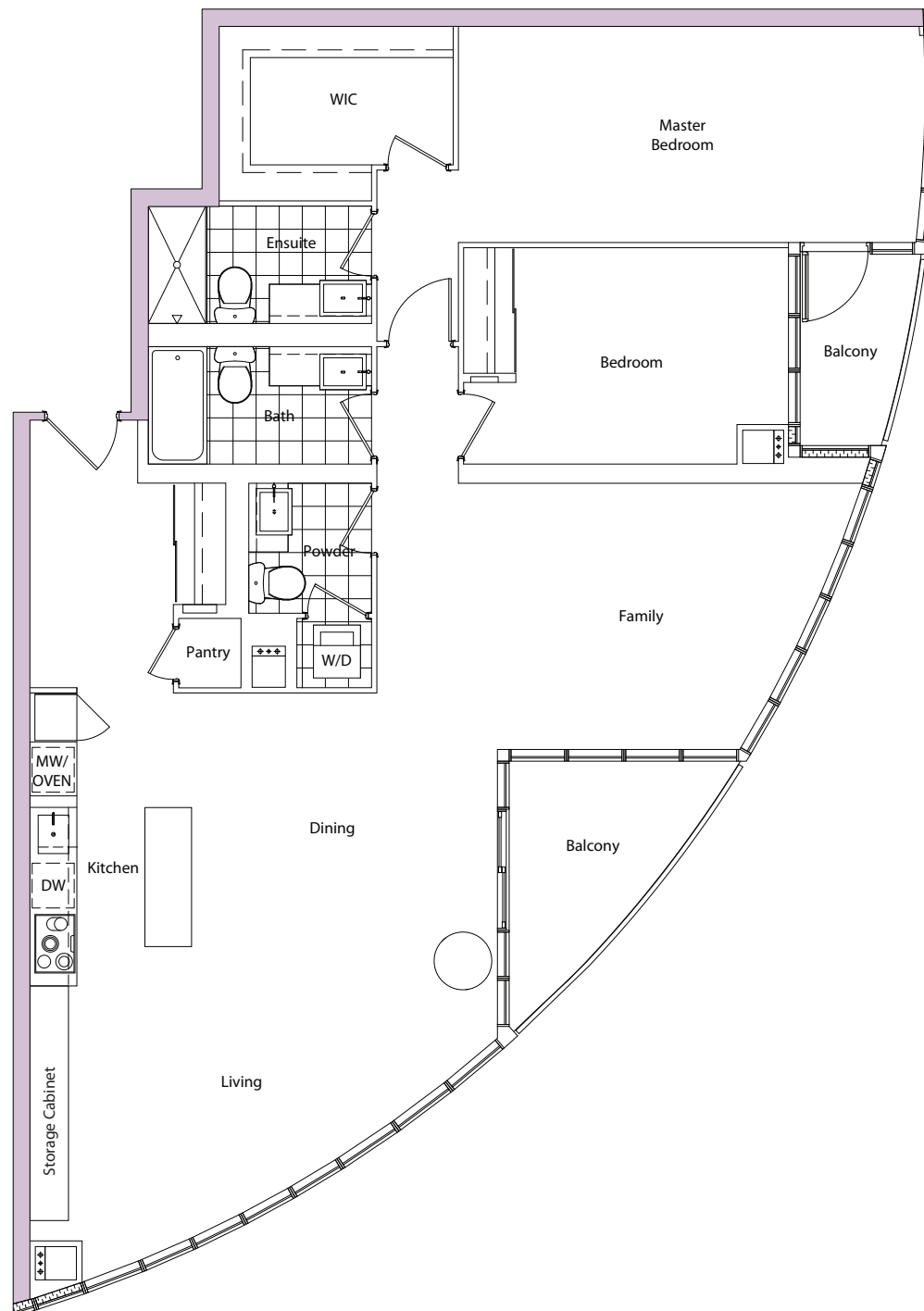

ONE BEDROOM  
+ DEN  
Suite 07

NET SUITE AREA / 718 SQ.FT.

BALCONY AREA / 38 SQ.FT.

TOTAL NET AREA / 756 SQ.FT.

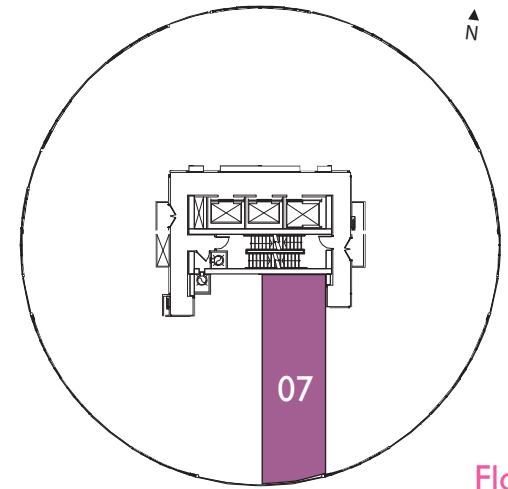

Floors 37-48

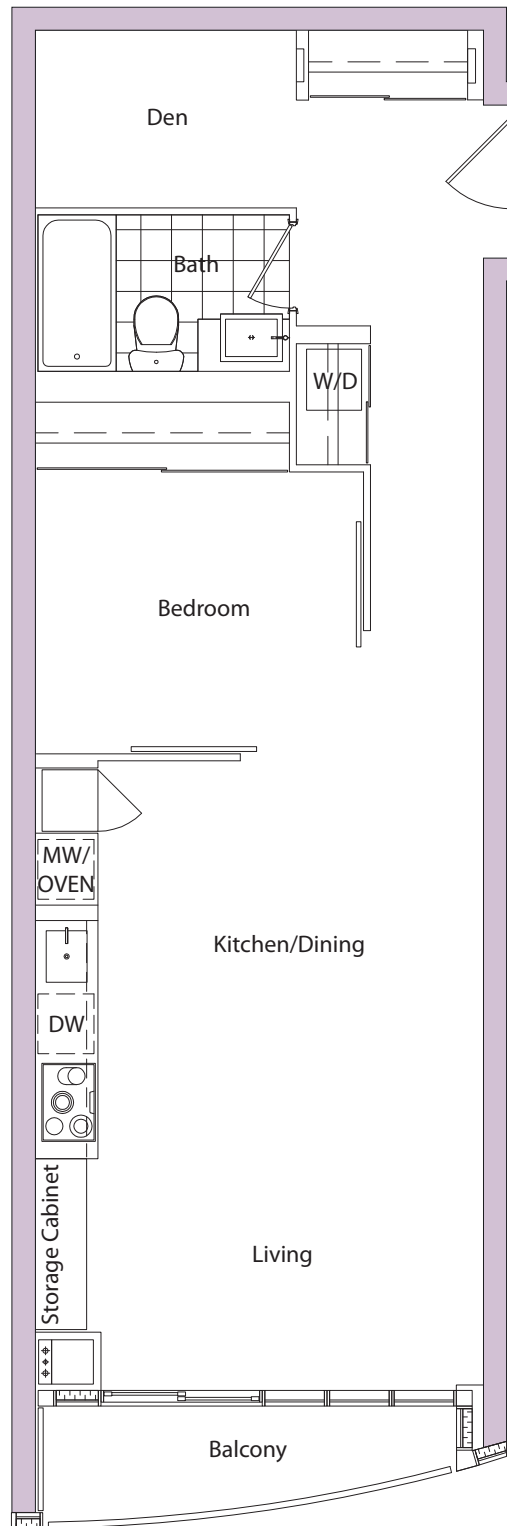

ONE BEDROOM  
+ DEN  
Suite 08

NET SUITE AREA / 688 SQ.FT.

BALCONY AREA / 38 SQ.FT.

TOTAL NET AREA / 726 SQ.FT.

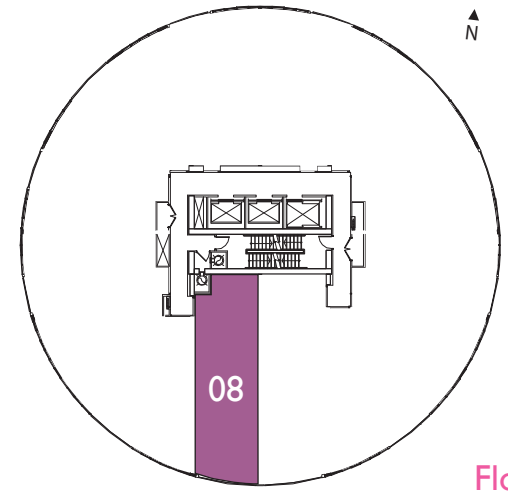

Floors 37-48

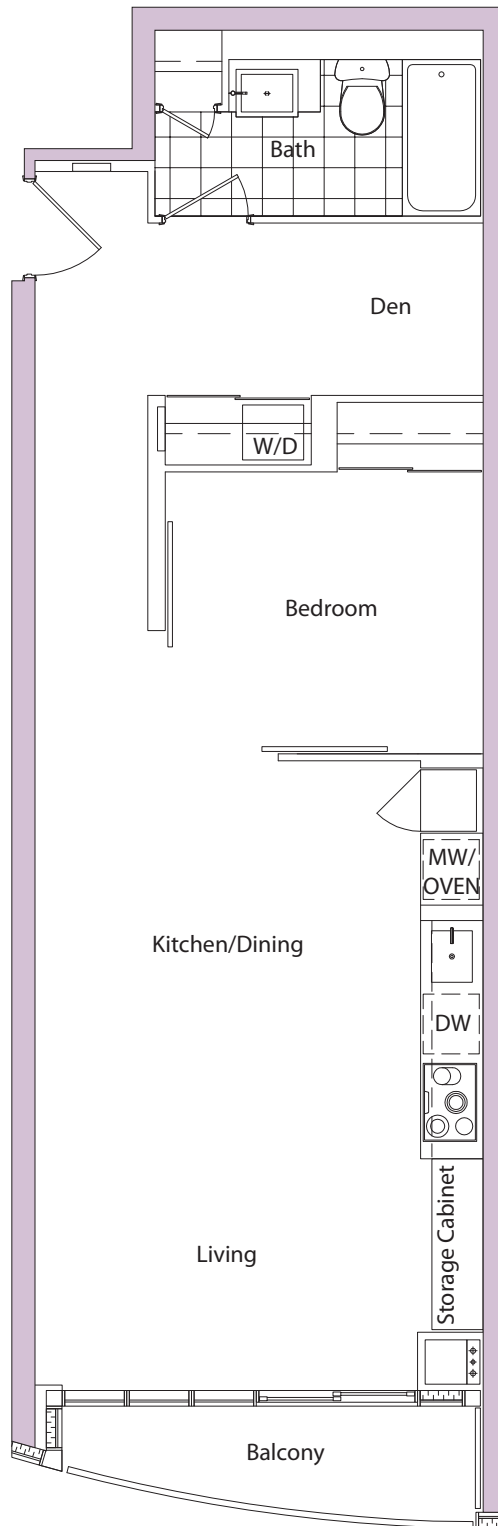

# TWO BEDROOM + FAMILY ROOM

Suite 10

NET SUITE AREA / 1,432 SQ.FT.

BALCONY AREA / 98 SQ.FT.

TOTAL NET AREA / 1,530 SQ.FT.

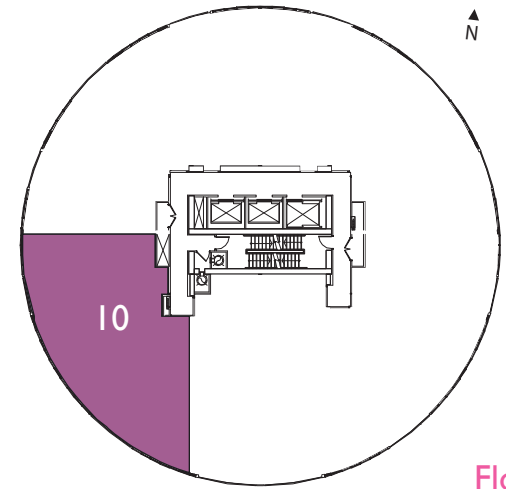

Floors 37-48

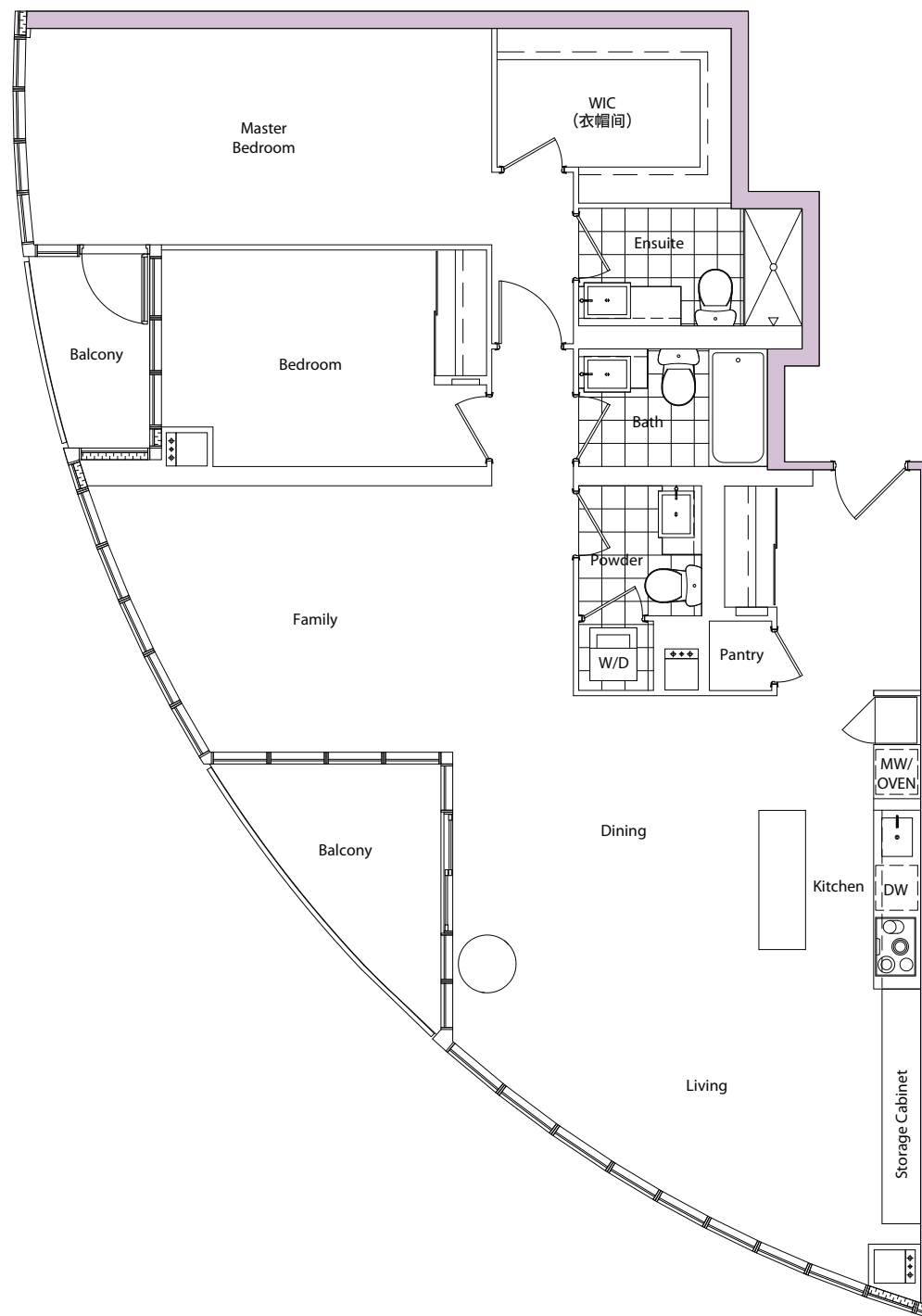

ONE BEDROOM  
+ DEN  
Suite 11

NET SUITE AREA / 573 SQ.FT.  
BALCONY AREA / 35 SQ.FT.  
TOTAL NET AREA / 608 SQ.FT.

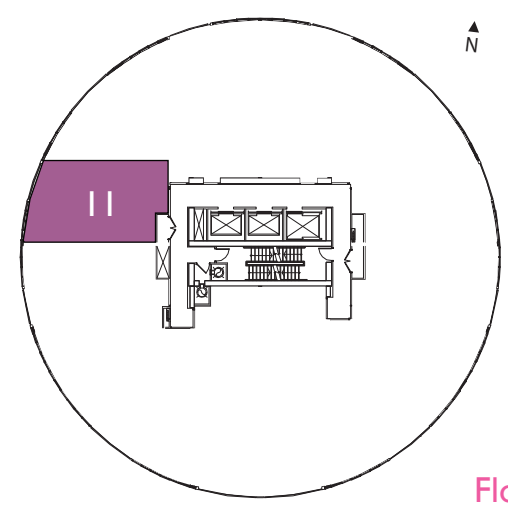

Floors 37-49

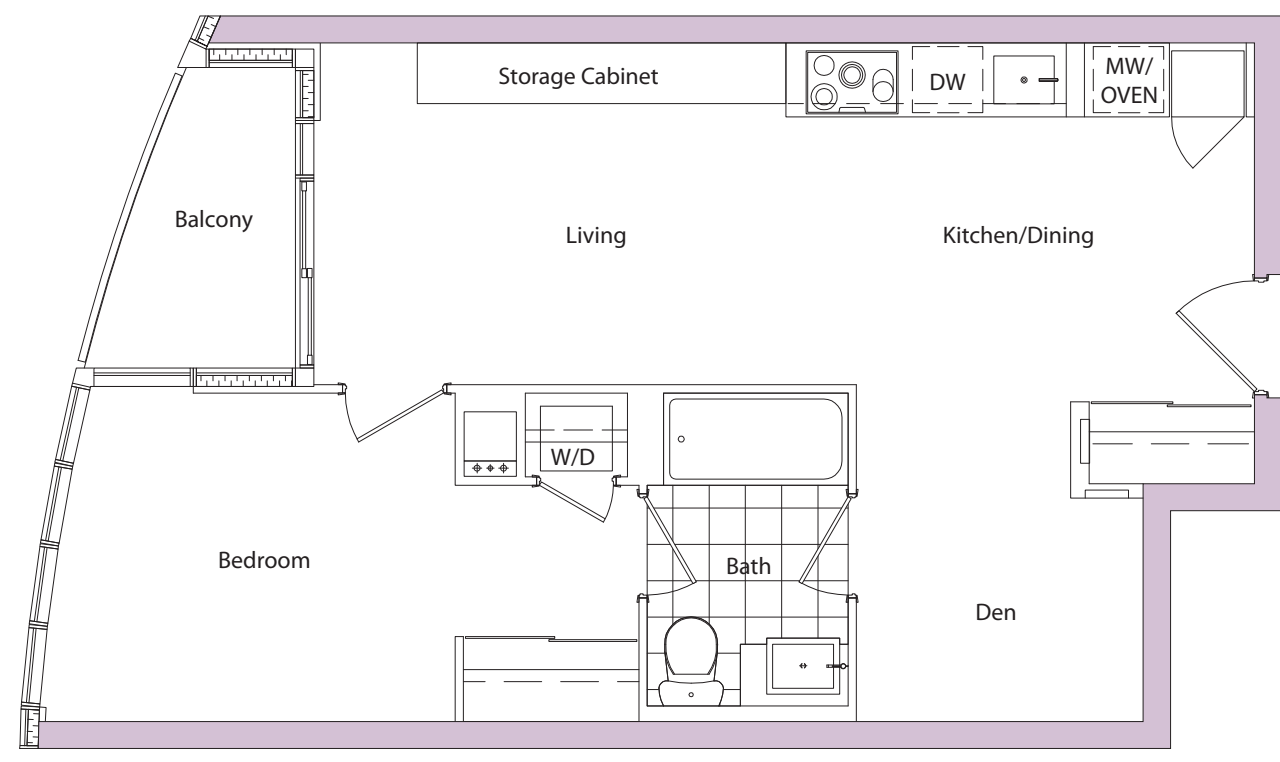



# ONE BEDROOM

Suite 12

NET SUITE AREA / 550 SQ.FT.

BALCONY AREA / 35 SQ.FT.

TOTAL NET AREA / 585 SQ.FT.

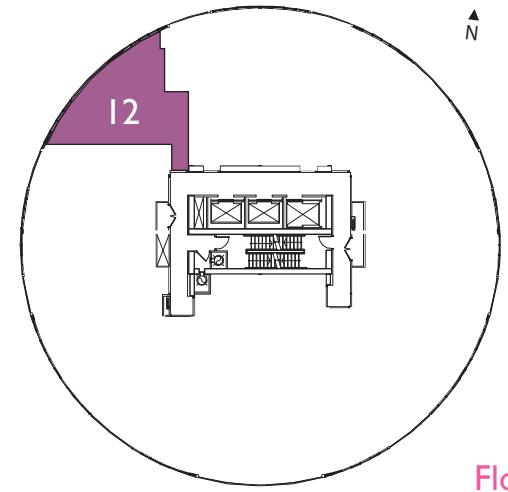

Floors 37-49

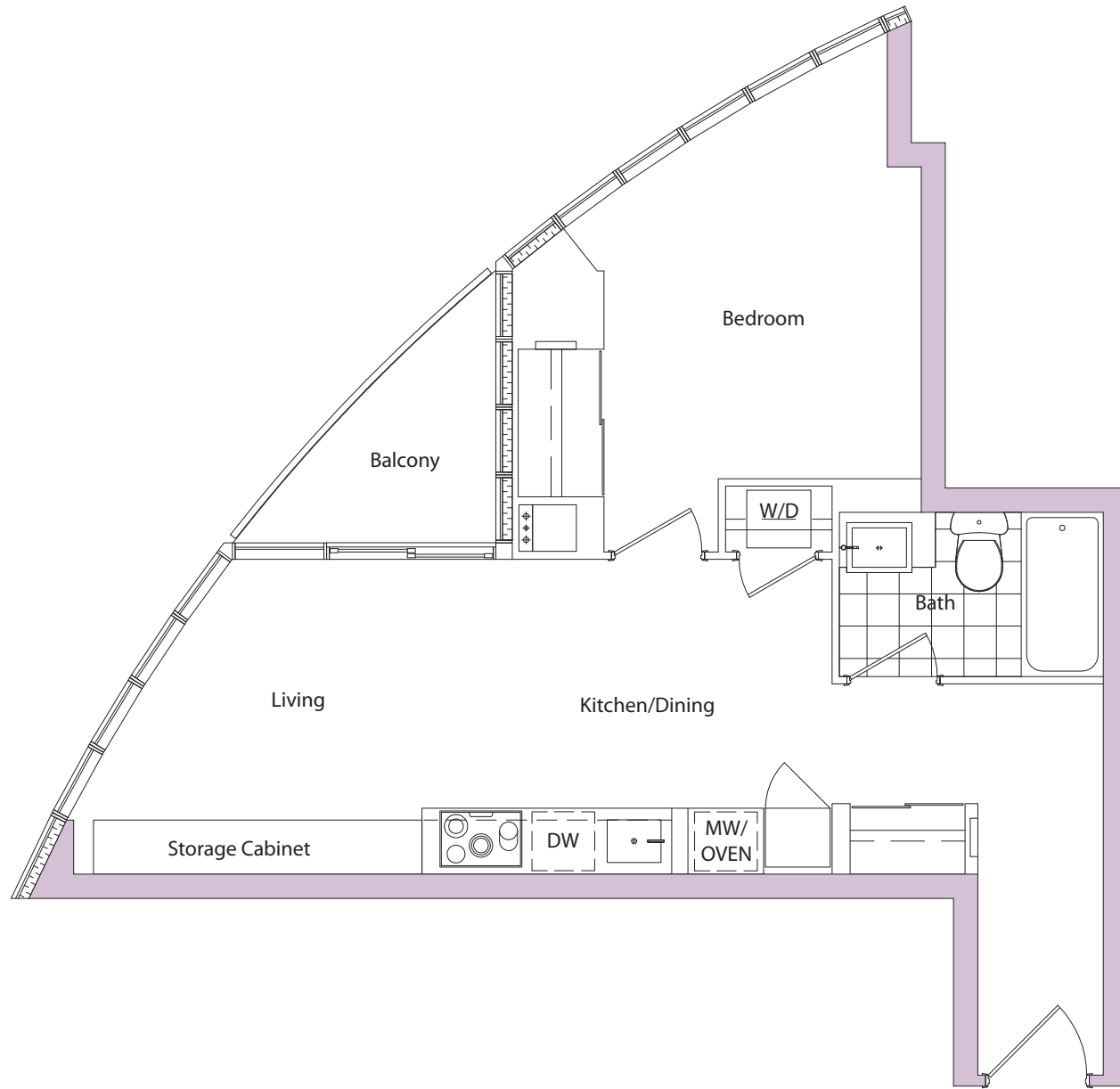

ONE BEDROOM  
+ DEN  
Suite 15

NET SUITE AREA / 638 SQ.FT.

BALCONY AREA / 35 SQ.FT.

TOTAL NET AREA / 673 SQ.FT.

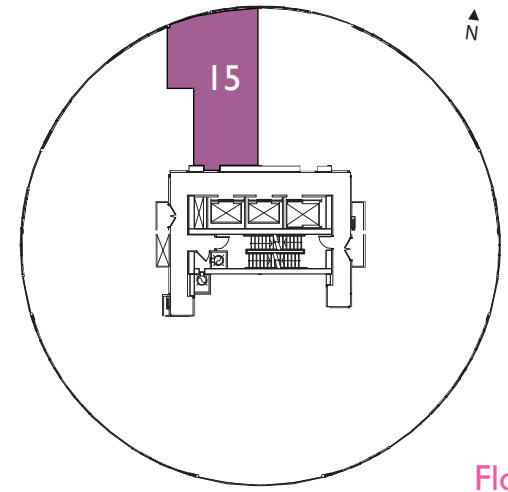

Floors 37-49

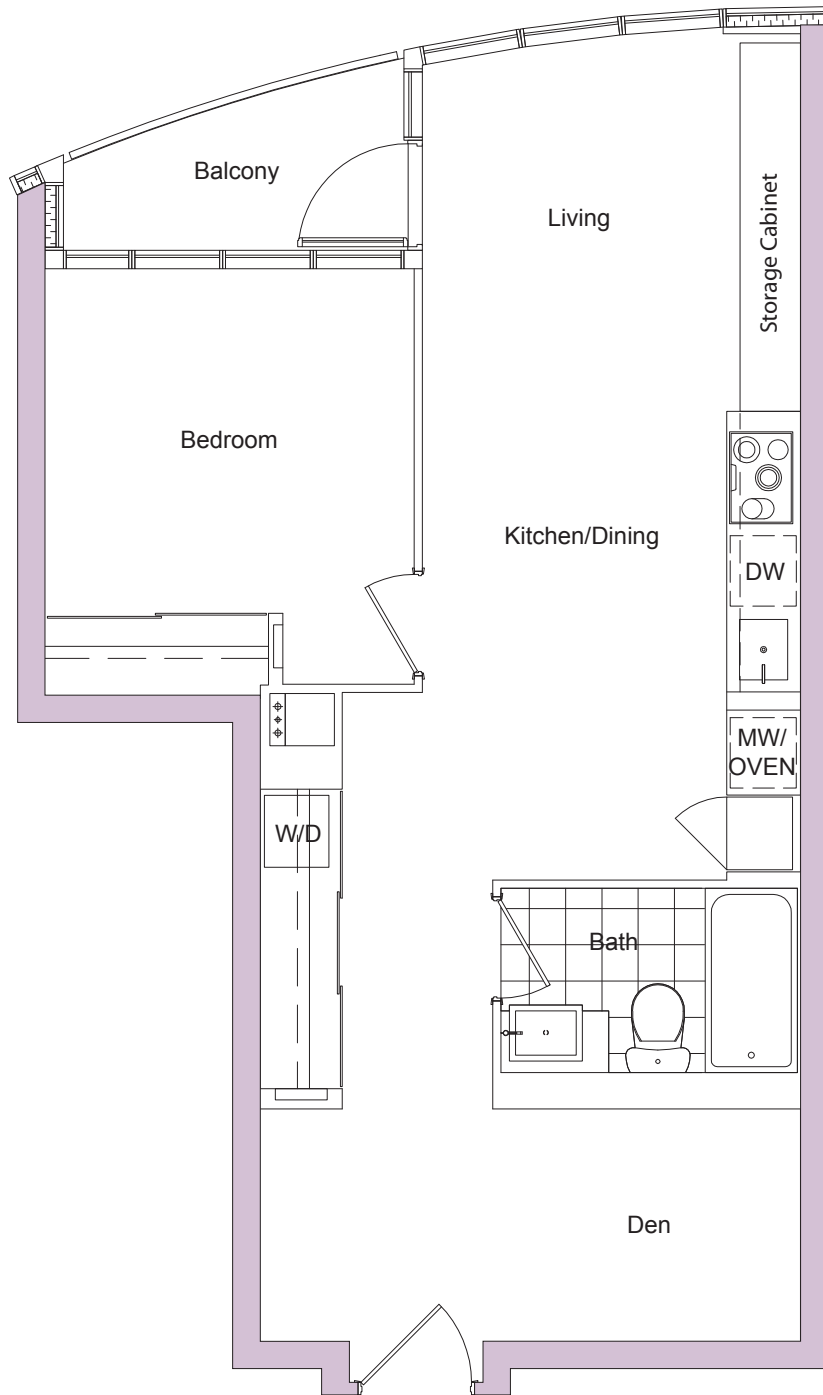

The developer reserves the right to make minor revisions to interior wall locations and exterior window system. All materials and drawing are approximate. Information is subject to change without notice. Actual square footage may vary from the stated floor plan. E. & O.E.